

# ALDERON

## Big Switch™ Series Float Switches

---

**Alderon – Big Switch™ Series Float Switches** are rated at 15 amps, which allows the switches to be used on both small and large horsepower pumps.

**Alderon – Big Switch™ Series Float Switches** are also environmentally safe with a patented mechanical switching mechanism that eliminates the use of hazardous mercury. The high quality design utilizes a high number of fine stranded copper wires which makes for an extremely flexible – long life cable.



### Benefits

- High Amp Rating
- Environmentally Safe
- High Integrity Design

### Features

- Patented Mechanical Design
- PVC Float Housing
- Heavy Duty Cable
- Omni-Directional
- UL Listed / 3 Year Warranty

### Applications

- Normally Open (Pump Down): The **Alderon – Big Switch™ Series Float Switch** turns on (closes) when the float is 45 degrees above horizontal, turning on the pump, and turns off (opens) when the float drops 45 degrees below horizontal, turning off the pump.
- Normally Closed (Pump Up): The **Alderon – Big Switch™ Series Float Switch** turns on (closes) when the float is 45 degrees below horizontal, turning on the pump, and turns off (opens) when the float drops 45 degrees above horizontal, turning off the pump.

Know Higher Standards™

---

# ALDERON Big Switch™ Series Float Switches

## Product Specifications

Part Number	Amperage	Plug	Pump Up / Down	Float Housing D x L (in / cm)	Housing	Switching Differential (in / cm)	Cable	Cable Length (ft)
200916	15 amps @ 110V	Piggy Back	Down	3.25 x 4.50 / 8.25 x 11.43	High Impact PVC	90 Degrees: Pump Range 8 - 22 / 20.3 - 55.9	Flexible 14 Gauge, 2 Conductors, SJOOW (UL, CSA), Water Resistant, Rubber (CPE)	20
200917	15 amps @ 220V	None	Up	3.25 x 4.50 / 8.25 x 11.43	High Impact PVC	90 Degrees: Pump Range 8 - 22 / 20.3 - 55.9	Flexible 14 Gauge, 2 Conductors, SJOOW (UL, CSA), Water Resistant, Rubber (CPE)	20
200918	15 amps @ 110V	Piggy Back	Down	3.25 x 4.50 / 8.25 x 11.43	High Impact PVC	90 Degrees: Pump Range 8 - 22 / 20.3 - 55.9	Flexible 14 Gauge, 2 Conductors, SJOOW (UL, CSA), Water Resistant, Rubber (CPE)	20
200919	15 amps @ 220V	None	Up	3.25 x 4.50 / 8.25 x 11.43	High Impact PVC	90 Degrees: Pump Range 8 - 22 / 20.3 - 55.9	Flexible 14 Gauge, 2 Conductors, SJOOW (UL, CSA), Water Resistant, Rubber (CPE)	20

Note: Alderon - Big Switch™ Series Float Switches must be used with motors that provide integral thermal overload protection.

## Piggy Back Installation

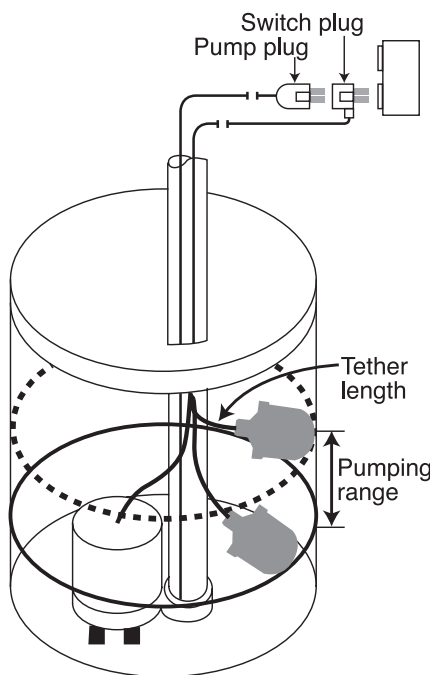

### Determining Pumping Range in Inches

Tether Length	Pumping Range
4	8
5	9
6	10
7	11
8	12
9	13
10	14
11	15
12	16
16	20
17	21
18	22

Use only as a guide. Pumping ranges are based on testing in non-turbulent conditions. Range may vary due to water temperature and cord shape. NOTE: As the tether length increases, so does the variance of the pumping range.

## Direct Wire Installation

