

INOX PREMIER HIGH FLOW FILTER HOUSING

PFH-SGB-2HF-40-4F-GP-ML

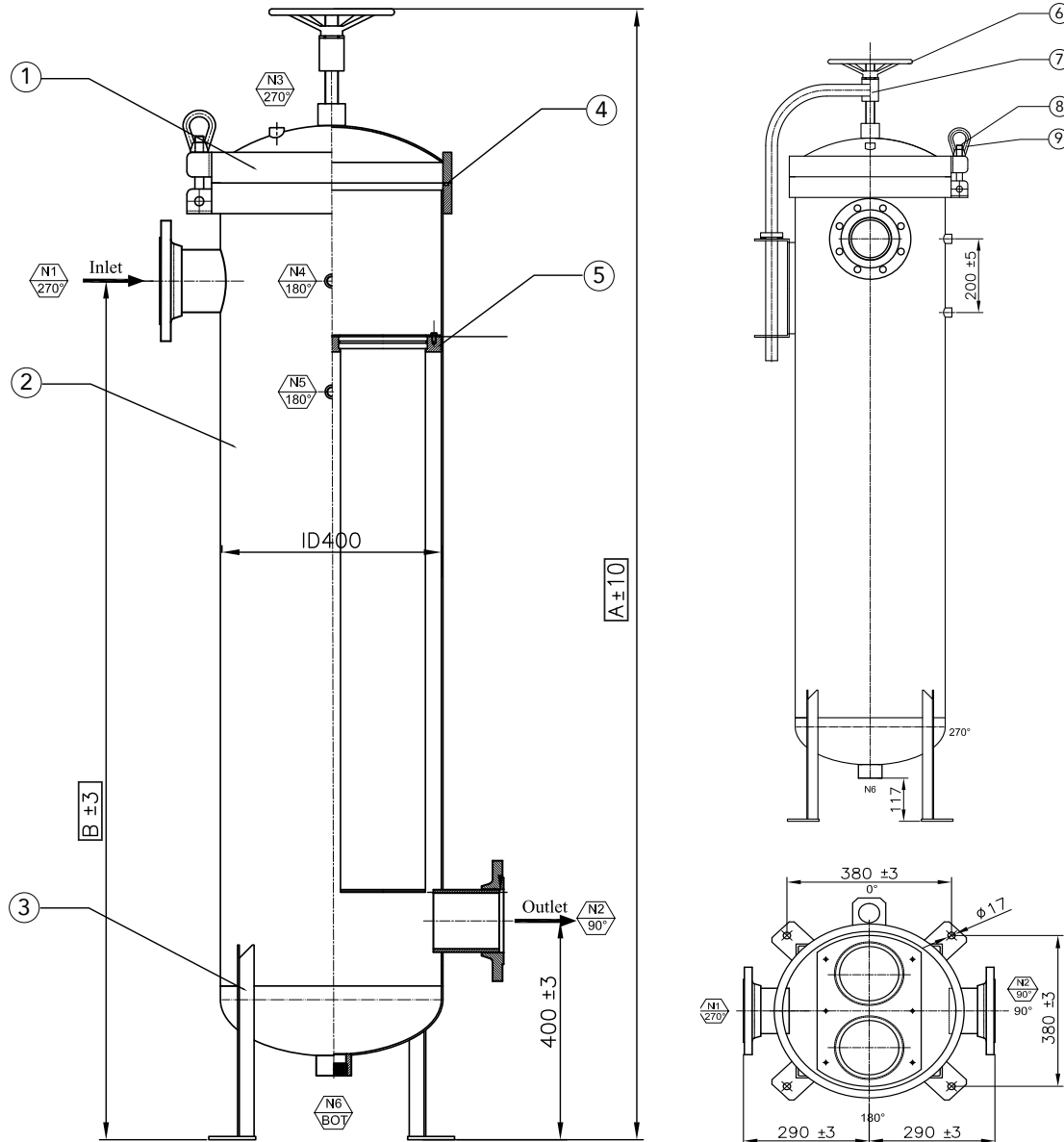

Overall Dimensions		
To Accommodate Filter Qty x Length	A mm	B mm
2 x 40"	2068	1570

Port Details					
No.	Type	Size	No.	Type	Size
N1	Inlet	DN100 PN16 (4" Flange)	N4	Gauge	1/2" BSPT-F
N2	Outlet	DN100 PN16 (4" Flange)	N5	Gauge	1/2" BSPT-F
N3	Vent	1/2" BSPT-F	N6	Drain	1 1/2" BSPT-F

Components					
No.	Name	Material	No.	Name	Material
1	Lid	316L	6	Davit Wheel	304
2	Body	316L	7	Davit Arm	304
3	Legs (x4)	304	8	Nut (x6)	304
4	O-Ring	BUNA-N	9	Eye Bolt (x6)	304
5	Plate	316L			

Technical Information	Maximum Operating Temperature	120°C	
	Pressure relief device should be installed on the outer piping by the customer to assure that pressure in the vessel can not exceed the design pressure indicated.	Design Pressure	7 bar
	All dimensions are approximate in mm.	Hydrostatic Test Pressure	10 bar