

FLOW UP TO 600 LPM

The largest of the single-round range, the size 2 stainless steel bag housings provide a solution to high flow rate and bulk solid removal applications. With high dirt loading capabilities, systems and processes can stay online for longer.



PED
Compliant
Article 4, Paragraph 3, Group 2 Liquids

DWI
Approved

FDA
Compliant Materials

MATERIALS OF CONSTRUCTION



- Body & Lid: Polycoated 316L Stainless Steel
- Basket: 316L Stainless Steel
- Legs: 304 Stainless Steel
- V-band Clamp: 304 Stainless Steel (SBH Only)
- O-rings: Buna-N

TECHNICAL DATA



Pressure Rating (bar)	10
Temperature Rating (°C)	120
Flow Rate (LPM)	600

DIMENSIONS

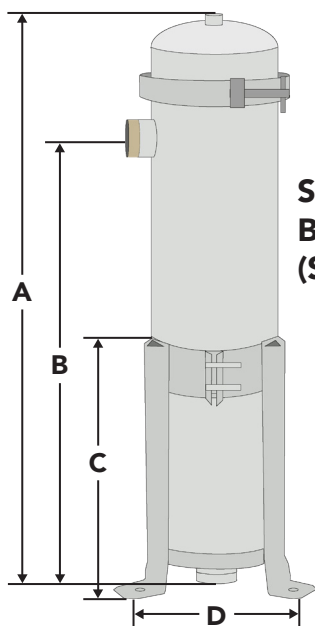

**STANDARD
BAG HOUSING
(SBH)**

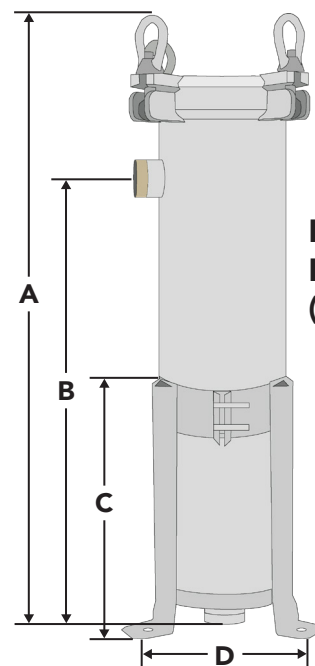

**PREMIER BAG
HOUSING
(PBH)**

Dimensions (mm)				
Code	A	B	C	D
SBH-SPC-1-2-2-GP-ML	1132	955	560	322.5
PBH-SPC-1-2-2-GP-ML	1095	884	560	322.5

ORDERING GUIDE



Code	No. of Bags	Bag Size	Port Size (")	Gauge Ports	Gauges	Mounting Legs
SBH-SPC-1-2-2-GP-ML	1	2	2" BSPM	✓	Optional	✓
SBH-SPC-1-2-3-GP-ML	1	2	3" BSPM	✓	Optional	✓
PBH-SPC-1-2-2-GP-ML	1	2	2" BSPM	✓	✓	✓
PBH-SPC-1-2-3-GP-ML	1	2	3" BSPM	✓	✓	✓
PBH-SPC-1-2-2F-GP-ML	1	2	2" DN50	✓	✓	✓
PBH-SPC-1-2-3F-GP-ML	1	2	3" DN80	✓	✓	✓

PRODUCT RANGE



The below products have often been associated with this product.



Size 3&4

Flow up to 150 lpm



Size 1

Flow up to 300 lpm



Size 2

Flow up to 600 lpm



Multi Round

Flow up to 4000 lpm