

SANITARY - UP TO 560 LPM

The largest variation in the Inox Sanitary housing range, the 7 round provides a comprehensive solution for precise applications up to 560 litres per minute. Implementing industry specified and user-focused features, these larger vessels do not compromise in terms of quality or functionality. With a sanitary pressure gauge, vent and drain ports, floor mountable legs, as well as blanking plates for any unused ports, the range is supplied as a complete package for peace of mind.

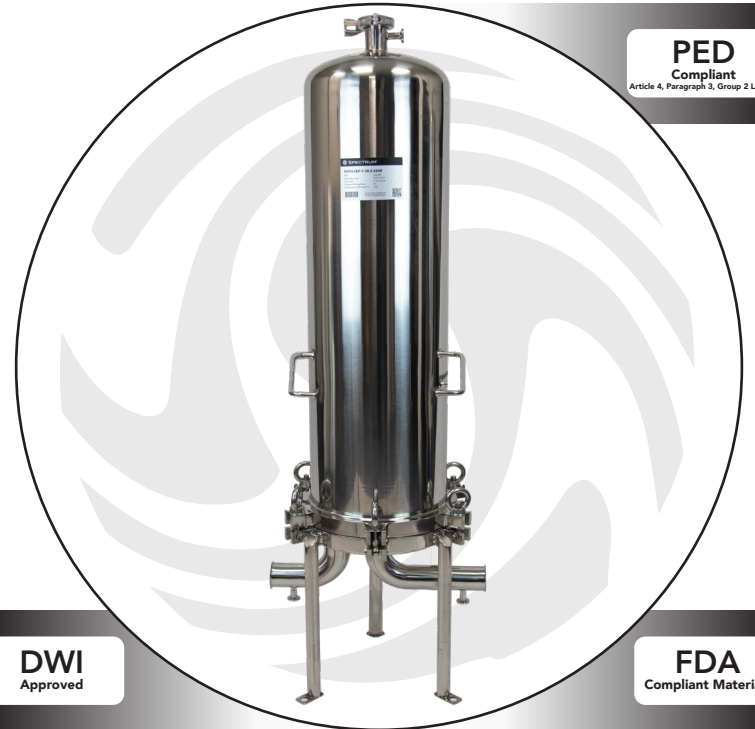

FEATURES & BENEFITS



- 0.3µm Ra internal surface finish
- Tri-clamp ports for industry compatibility
- Diaphragmed pressure gauge included for filter monitoring
- Vent / test port for pressure release and integrity testing
- Accepts 226 end-cap for added security

MATERIALS OF CONSTRUCTION



Body & Base: 316L Stainless Steel
 Internal Surface Finish: ≤0.3µm Ra
 External Surface Finish: ≤0.4µm Ra
 Housing Seal: EPDM
 Clamp & Legs: 304 Stainless Steel

TECHNICAL DATA



Port Sizes (")	2 Tri-Clamp
Cartridge Compatibility (")	30, 40
End-Cap Compatibility	226
Pressure Rating* (bar)	12.5
Temperature Rating (°C)	150

*Hydrostatic pressure rating.

DIMENSIONS

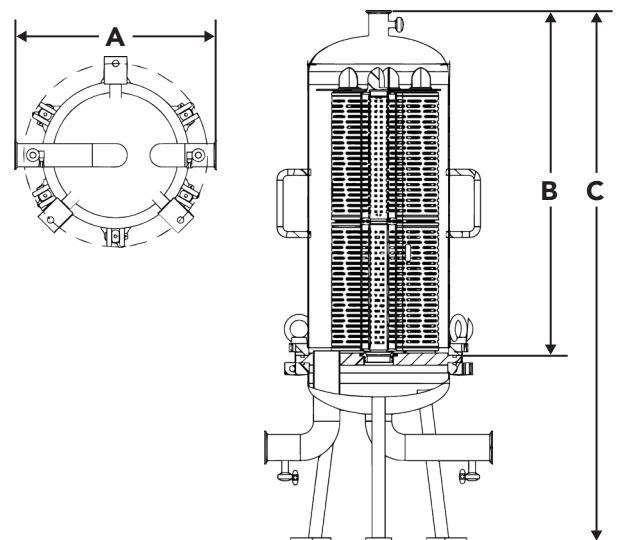

Dimensions (mm)			
Housing	A	B	C
PSFH-SEP-7-30	440	944	1288
PSFH-SEP-7-40	440	1194	1538

FLOW RATE 



420

30"

560

40"

Pleated

ORDERING GUIDE 

Code	Description
PSFH-SEP-7-30-2-226E	SPECTRUM Sanitary Filter Housing 7 X 30 226 End-Cap 2" Tri-Clamp EPDM Seal
PSFH-SEP-7-40-2-226E	SPECTRUM Sanitary Filter Housing 7 X 40 226 End-Cap 2" Tri-Clamp EPDM Seal

PRODUCT RANGE 

The below products have often been associated with this product.



1 Round

Flow up to 60 lpm



3 Round

Flow up to 180 lpm



5 Round

Flow up to 400 lpm



7 Round

Flow up to 560 lpm